

# ENGINE IDENTIFICATION

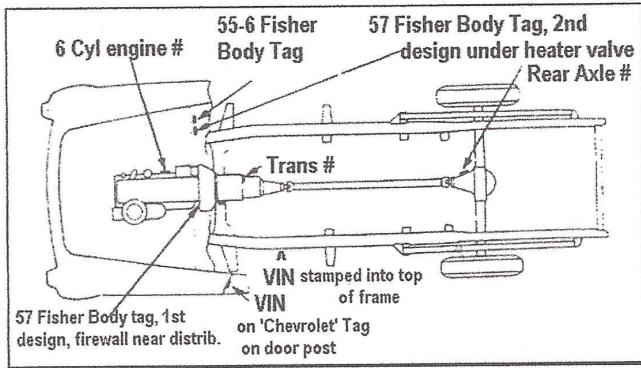

| SERIES | TYPE                                  | PLANT I.D. |         |
|--------|---------------------------------------|------------|---------|
|        |                                       | G. & A.    | Buffalo |
| PASS.  | 3-Speed .                             | AA         | BA      |
| PASS.  | Automatic Transmission.               | AB         | BB      |
| PASS.  | Overdrive                             | AC         | BC      |
| PASS.  | 3-Spd. w Positraction (3.55 ratio)    | AK         |         |
| PASS.  | Overdrive w Positraction (4.11 ratio) | AL         |         |
| PASS.  | A.T. w, Positraction (3.36 ratio)     | AM         |         |

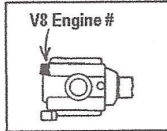

### Original Radiator Numbers

|         |                       |
|---------|-----------------------|
| 3133042 | 6 cyl Sick, 55-6      |
| 3133043 | 6 cyl Automatic, 55-6 |
| 3133044 | V8 Sick, 55           |
| 3133045 | V8 Automatic, 55      |
| 3136157 | V8 Sick, 56-7         |
| 3136158 | V8 Automatic, 56-7    |
| 3136569 | 6 cyl Sick, 57        |
| 3136570 | 6 cyl Automatic, 57   |
| 3137077 | V8 Turboglide, 57     |

SOURCE DESIGNATION: F-Flint T-Tonawanda.  
MODEL YEAR DESIGNATION: 55

| Series      | Description                           | Type Designation |
|-------------|---------------------------------------|------------------|
| 15-21-2400  | '235' 6 Cyl. - 3-Speed O D.           | Z                |
| 15-21-2400, | TAXI-CAB '235' 6 Cyl. - H D Clutch... | ZC               |
| 15-21-2400  | '235' 6 Cyl. - 3-Speed -              |                  |
| TAXI-CAB    | '235' 6 Cyl. - H D Clutch             | ZC               |
| 15-21-2400  | '235' 6 Cyl. - 3-Speed -              |                  |
|             | Aluminum Camshaft Gear                | ZH               |
| 15-21-2400  | '235' 6 Cyl. HD Clutch -              |                  |
|             | Aluminum Camshaft Gear                | ZJ               |
| 15-21-2400  | '235' 6 Cyl. - Powerglide             | Y                |
| 15-21-2400  | '265' V8 - 3-Speed Trans.             | G                |

SOURCE DESIGNATION: F-Flint T-Tonawanda.  
MODEL YEAR DESIGNATION: 56

| Series     | Description                  | Type Designation |
|------------|------------------------------|------------------|
| 15-21-2400 | '235' 6 Cyl. - 3-Speed O D   | Z                |
| 15-21-2400 | '235' 6 Cyl. - H.D. Clutch   | ZC               |
| 15-21-2400 | '235' 6 Cyl. - Powerglide    | Y                |
| 15-21-2400 | '265' V8 - 3-Speed Trans     | G                |
| 15-21-2400 | '265' V8 - Overdrive         | GC               |
| 15-21-2400 | '265' V8 - 4BC               | GL               |
| 15-21-2400 | '265' V8 - Dual 4BC          | GS               |
| 15-21-2400 | '265' V8 Dual 4BCHI-Lift Cam | GT               |
| 15-21-2400 | '265' V8 - 4BC - AC          | GM               |

SOURCE DESIGNATION: F-Flint T-Tonawanda C-Canada

STARTING UNIT NUMBER: The three or four digit number following the source designation will designate the calendar month and date produced. The last two digits will always designate the date, viz., (01) for the first day of the month, (10) for the 10th day etc. The one or two digits preceding the date produced will designate the month, viz., (1) for January, (11) for November.

| Series     | Description                     | Type Designation |
|------------|---------------------------------|------------------|
| 15-21-2400 | '235' 6 Cyl. - 3-Speed and O D  | A                |
| 15-21-2400 | '235' 6 Cyl. - H.D. Clutch      | AD               |
| 15-21-2400 | '235' 6 Cyl. - Powerglide       | B                |
| 15-21-2400 | '265' V8 - 3-Speed Transmission | C                |
| 15-21-2400 | '265' V8 - Overdrive            | CD               |

| 1955         |                                |    |
|--------------|--------------------------------|----|
| 15-21-2400   | '265' V8 - Overdrive           | GC |
| 15-21-2400   | '265' V8 - 3-Speed Air Con.    | GF |
| 15-21-2400   | '265' V8 - Overdrive -A/C      | GQ |
| 15-21-2400   | '265' V8 - H.D. Clutch         | GJ |
| 15-21-2400   | '265' V8 -H.D. Clutch A/C      | GK |
| 15-21-2400   | '265' V8 - 3-Spd Duals 4BC     | GL |
| 15-21-2400   | '265' V8 - 3-Spd Duals 4BC AC  | GM |
| 15-21-2400   | '265' V8 Overdrive Duals 4BC   | GE |
| 15-21-2400   | '265' V8 O/drive Duals 4BC AC  | GN |
| 15-21-2400   | '265' V8 - Powerglide          | F  |
| 15-21-2400   | '265' V8 - P/G Duals 4BC       | FB |
| 15-21-2400   | '265' V8 - Powerglide -A/C     | FC |
| 15-21-2400   | '265' V8 - Powerglide - Dual   |    |
|              | Exhaust - 4BC - AC             | FD |
| 2900 (Vette) | '235' 6 Cylinder - Powerglide. | YG |

| 1956         |                               |    |
|--------------|-------------------------------|----|
| 15-21-2400   | '265' V8 - H.D. Clutch .      | GJ |
| 15-21-2400   | '265' V8 - H.D. Clutch -A/C   | GK |
| 15-21-2400   | '265' V8 - Overdrive -4BC     | GE |
| 15-21-2400   | '265' V8 - O/drive -A/C - 4BC | GN |
| 15-21-2400   | '265' V8 - Powerglide         | F  |
| 15-21-2400   | '265' V8 - Powerglide -4BC    | FB |
| 15-21-2400   | '265' V8 - P/G -Dual 4BC      | FH |
| 15-21-2400   | '265' V8 - Powerglide -A/C    | FC |
| 15-21-2400   | '265' V8 - P/G -A/C - 4BC     | FO |
| 2900 (Vette) | '265' V8 - 3-Speed Trans      | GV |
| 2900 (Vette) | '265' V8 Dual 4BCHI-Lift Cam  | GU |
| 2900 (Vette) | '265' V8 w/Dual 4BC           | GR |
| 2900 (Vette) | '265' V8 - Powerglide         | FK |

| 1957         |                                 |    |
|--------------|---------------------------------|----|
| 15-21-2400   | '265' V8 - H. D. Clutch .       | CE |
| 15-21-2400   | '283' V8 - 4BC                  | E  |
| 15-21-2400   | '283' V8 - Dual 4BC             | EA |
| 15-21-2400   | '283' V8 Dual 4BCHI-Lift Cam    | EB |
| 15-21-2400   | '283' V8 - Fuel Injection       | EJ |
| 15-21-2400   | '283' V8 - Fuel Inj Hi-Lift Cam | EK |
| 15-21-2400   | '283' V8 - Overdrive -4BC       | EC |
| 15-21-2400   | '283' V8 - Powerglide           | F  |
| 15-21-2400   | '283' V8 - Powerglide -A/C      | FA |
| 15-21-2400   | '283' V8 - Powerglide -4BC      | FC |
| 15-21-2400   | '283' V8 - P/G -Dual 4BC        | FD |
| 15-21-2400   | '283' V8 - P/G Fuel Injection   | FJ |
| 15-21-2400   | '283' V8 - P/G -4BC - A/C       | FE |
| 15-21-2400   | '283' V8 - Turboglide           | G  |
| 15-21-2400   | '283' V8 - Turboglide -4BC      | GC |
| 15-21-2400   | '283' V8 - T/G -Dual 4BC        | GD |
| 15-21-2400   | '283' V8 - T/G Fuel Injection   | GF |
| 2900 (Vette) | '283' V8 - 3-Speed Trans.- 4BC  | GF |

2900 (Vette) '265' 8 Cylinder - Powerglide FG  
2900 (Vette) '265' 8 Cylinder - 3-Speed GR  
\*MODEL YEAR DESIGNATION is 255 for Corvette 8 Cylinder with 3-Speed Transmission. EXAMPLE: The 65th 2400 Series six cylinder engine built at Flint to be used with Powerglide would be stamped 0001065F55Y. If built at Tonawanda it would have serial 0001065T55Y.

### CASTINGS #'S SEE INSIDE BACK COVER!!!

2900 (Vette) '265' V8 - P/G-Dual 4BC FG

EXAMPLE: The 50th 2100 Series 8 cylinder engine for overdrive transmission built at Flint carries Serial No. 0001050F56GC. If built at Tonawanda the serial number would be 0001050T56GC. NOTE: After October 1, 1956, past model series engines will show the latest year of application immediately preceding the source letter.

2900 (Vette) '283' V8 Dual 4BC -Hi-Lift Cam EG  
2900 (Vette) '283' V8 - Dual 4BC EH  
2900 (Vette) '283' V8 - Fuel Injection -Hi-Lift Cam w/A/C Air Intake EL  
2900 (Vette) '283' V8 - Fuel Inj Hi-Lift Cam EN  
2900 (Vette) '283' V8 - Fuel Injection EM  
2900 (Vette) '283' V8 - P/G -Dual 4BC FG  
2900 (Vette) '283' V8 - Powerglide FH  
2900 (Vette) '283' V8 - P/G Fuel Injection FK

EXAMPLE: A standard 2400 series type engine if built at Flint on March 1 would carry serial No. F301A. If built at Tonawanda on October 19 the number would be T1019A.